



Patient floors
Specialty areas
Satellite clinics

Laboratory
Pharmacy
Blood bank

High performance refrigerators and freezers

FOLLETT[®]

Designed Exclusively for Healthcare

Discussion Topics

- Trends driving facilities away from dorm and "commercial" refrigerators and freezers
- General considerations when selecting refrigerators for critical care applications
- Follett high performance countertop and undercounter refrigerators and freezers
- Follett high performance upright refrigerators and freezers

Industry trends driving high performance refrigeration needs

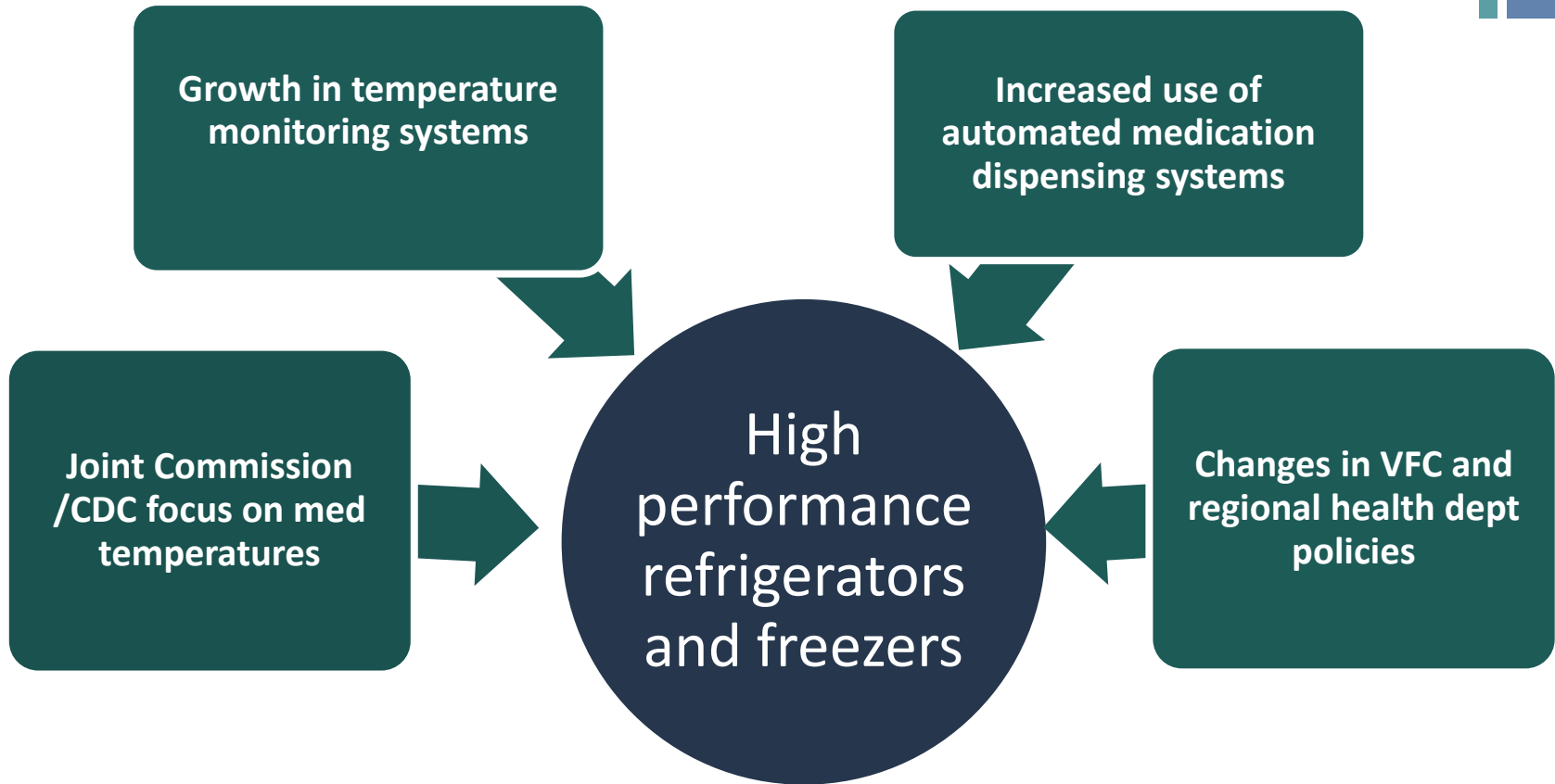

Important considerations for critical care refrigerators and freezers

- **Temperature performance**
 - The most important consideration!
 - Maintain temperature even with frequent door openings (pull-down and recovery)
 - Consistent cabinet-wide temperature
 - In-range temp even during defrost cycle
- **User interfaces**
 - Alarming and monitoring functions
 - Programming of user-selectable variables
 - C and F displays for different departments
- **Energy efficiency and environmental impact**
 - Energy consumption
 - General "green" design
- **Life cycle reliability**
 - Construction features
 - Servicing ease

Confusion around descriptive terminology

- "Commercial" means only that it has passed UL testing for safety
 - No testing for performance, cool down, recovery
- "Medical-grade" (initially coined by Follett) now being used for underperforming cold wall units
- NSF (National Sanitation Foundation) listing
 - Ensures that a 3rd party laboratory has tested for performance and confirms capability
 - Able to hold temperature in adverse ambients (100F)
 - Able to recover temperature after door openings



Follett Healthcare Refrigerators & Freezers

Manufactured to include

- True forced air refrigeration
- Stainless steel construction, inside and out
- Micro-processor temperature controller
- Audible and visual alarming functionality
- Medication dispensing system compatibility
- Automatic defrost
- Spring-loaded hinges
- Mechanical door lock
- 2 year parts & labor/5 year compressor warranty





Patient floors
Specialty areas
Satellite
facilities

Laboratory
Pharmacy
Blood bank

High performance **compact** refrigeration

- Undercounter refrigerators and freezers
- Countertop refrigerators

Why **FOLLETT**®

Countertop
refrigerators and
freezers

Undercounter
refrigerators and
freezers

- Consistent, stable temperature control
- Rapid pull down and recovery
- User-friendly features
- Heavy-duty construction details
- Temperature alarming
- Unmatched reliability, serviceability and customer support

High-performance countertop refrigerators and freezers!



Minimum size — maximum performance!

- Superior performance
 - Heavy-duty compressor delivers superior pull down
 - Forced air cooling provides immediate temperature recovery, even with frequent door openings
 - Quiet compressor and coaxial fans allow use in noise-sensitive areas
- Convenience and security in a feature-rich interface
 - LED controls display product temperature in user-selectable F or C
 - Audible and visual high/low alarms provide protection for valuable stored products
 - Optional keypad & electronic access available on all models



The right fit for healthcare applications

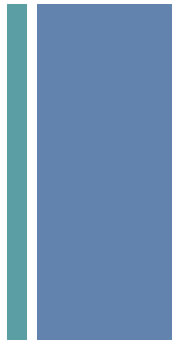

Med rooms, auxiliary dispensing cabinets, wall mount

- Easier, more ergonomic access than undercounters
- Two models – both with space-saving footprints
 - 1 and 2 cu ft models fit on standard 24" counters without overhang
 - Compatible with medication dispensing system locks with no additional hardware
 - REF1/FZR1 height is less than 18" for use below overhanging cabinets
 - Wall mount accessory allows installation above counter or other equipment



Performance Plus undercounter refrigerators & freezers

Unequaled performance for real-world applications

- Superior temperature performance for a demanding environment
- Stainless steel construction with CFC-free polyurethane insulation
- Top-mounted digital temperature display
- Reversible door with replaceable dart-style gasket
- Mechanical lock
- Front on/off power switch
- Adjustable nylon leveling feet
 - Optional dual-wheel, locking casters for easy cleaning



Cabinet design

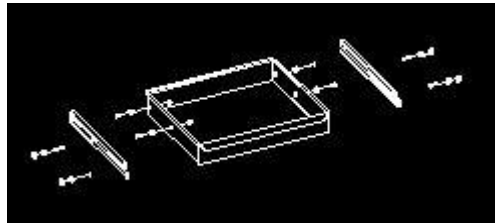

- Two sizes – REF4P/FZR4P and REF5P/FZR5P
 - Both 23.8" W x 25.6" D
 - REF4P/FZR4P = 31.4"H;
REF5P/FZR5P = 34.0"H
- Storage capacity
 - REF4P/FZR4P = 3.9 cu ft
 - REF5P/FZR5P = 4.5 cu ft
- All models feature forced-air backwall cooling unit
- Recessed floor for easy cleaning meets NSF requirement
- Internal configuration (REF/FZR 4/5P)
 - Shelves and drawers are interchangeable and can be used in combination



Universal ADC Bracket



- Universal door bracket allows Follett Performance Plus refrigerators and freezers to be used with all automated medication dispensing locking systems

- Brushed aluminum adapter mounts to side of door to create 90 degree angle flush with side of cabinet

- Attaches with
 - 3 screws onto side of door

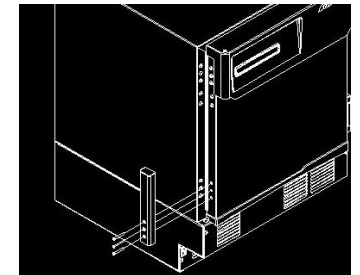

- Facilitates installation of any automated medication dispensing system locks

All Units are Stackable



- Stacking kits are available to save floor space
 - Kit includes hardware to stack two high
 - Bottom unit requires flush-front kick panel for stability
 - **Two** flush-front panels are Included as part of stacking kit accessory
 - Field-installed by customer
- Stacking brackets also serve as seismic brackets

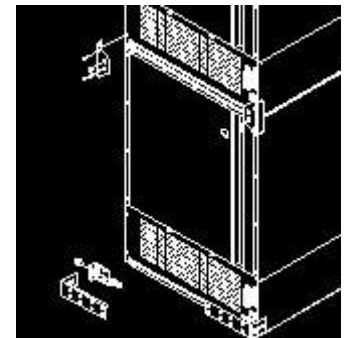



Laboratory

Pharmacy

Blood bank

Med rooms

Satellite facilities

Healthcare's most advanced line of upright refrigerators & freezers

What makes

FOLLETT[™]

uprights
different...and
better

- Powerful, modular refrigeration system
- Plenum-ducted forced air distribution
- Full stainless interior and exterior
- Important, energy-saving features
- Complete alarming, monitoring, data streaming
- Superior storage options

Powerful modular refrigeration unit

- Single integral module replaces other manufacturers' "split systems" where evaporators hang inside the cabinet
- Entire refrigeration system removes as one unit and can be replaced in < 15 minutes
- Rapid pull-down and recovery following door openings

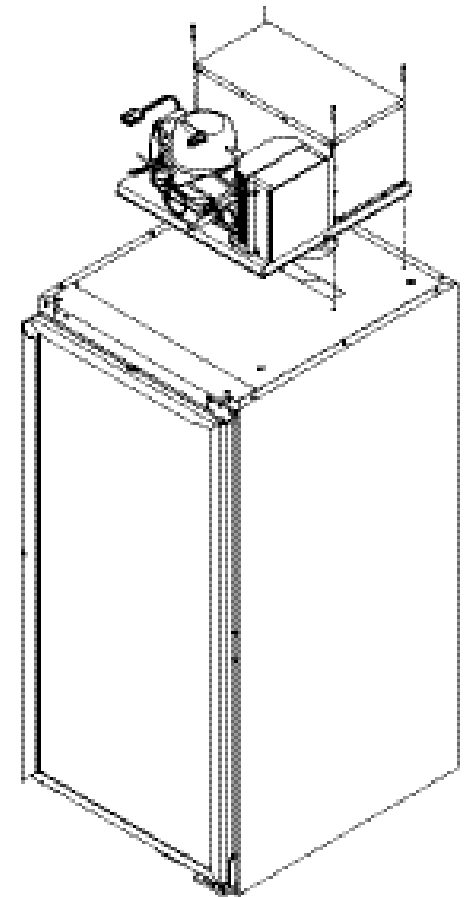

Superior air distribution system

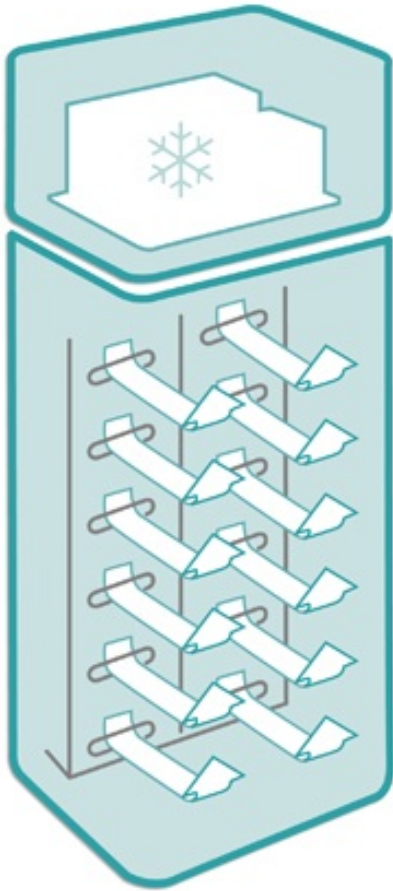

- The most advanced airflow system in the industry forces cold air down through back plenums to 12 separate ports
- Multiple air flow points replace single top mounted fan of competitive units
- Ensures consistent cooling at all levels, even with heavily loaded shelves, drawers or baskets

Standard with all alarming/monitoring for critical product storage



- Easy-to-read 3” graphical display in C or F
- Intuitive navigation via front interface buttons
- Complete alarming and monitoring
 - High/low temp
 - Door ajar
 - Power failure
 - Low battery
 - Probe failure
 - RS-485 port and dry contacts
- Integral chart recorder standard for blood bank; option on other models

Compatible with major automated medication dispensing systems



Follett upright refrigerator shown with Omnicell automated dispensing system

- Follett bracket accessories provide compatibility with
 - Pyxis Remote Manager®
 - Omnicell FlexLock®
 - McKesson Lynx®
 - Metro MedDispense®
 - Amerisource Bergen MedSelect®
- McKesson has designed a bracket specifically for AcuDose® compatibility with Follett upright refrigerators
- Follett's soft tan and stainless color scheme compliments automated dispensing system colors

The industry's "greenest" refrigerators

Important energy-saving features



- Superior double pane glass doors with Low-E coating reduce energy loss by 30 – 50%
- Industry's coolest, most energy-efficient lighting – full-length LED light bars consume significantly less energy than, emit virtually no heat
- Full 2.75" CFC-free foam insulation around entire cabinet means less conduction heat loss, run time and power consumption than others (R-value 17)
- Recyclable stainless steel cabinet eliminates waste stream issues associated with powder coating
- Low ODP and GWP R-134a refrigerant supports LEED standards

Healthcare's Most Advanced Line of Upright Freezers



- Laboratory
- Plasma

Heavy Duty Solid Stainless Steel Door



- Solid 2.6" (7cm) thick insulated stainless steel door with ADA-compliant full-length locking handle
 - R value 14.8
- Fascia heater prevents condensation and frost/ice buildup
- Santoprene® magnetic gasket

User-friendly features

- Standard right hinge (LH as option)
- ADA-compliant full length handle
- Self-closing hinges
- Locks open at 90 degrees for easier product loading
- Inset hinge allows full opening next to wall or other equipment